

# CATFORD

Jamestown

SA 5491

# ENGINEERING PRODUCTS

All Prices Excluding GST

Phone: 0418 641 566

[www.catford.com.au](http://www.catford.com.au) [sales@catford.com.au](mailto:sales@catford.com.au)

**HYDRAFORCE** ELECTRONICS

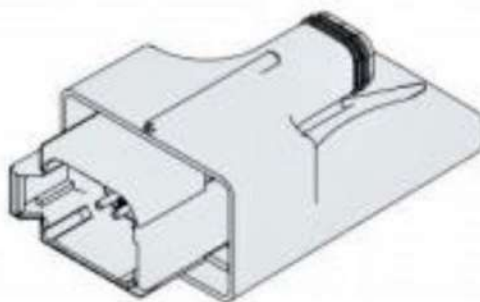

Please call or email for prices and availability.

**CATFORD**  
**ENGINEERING**  
**PRODUCTS**

**Jamestown**  
**SA 5491**

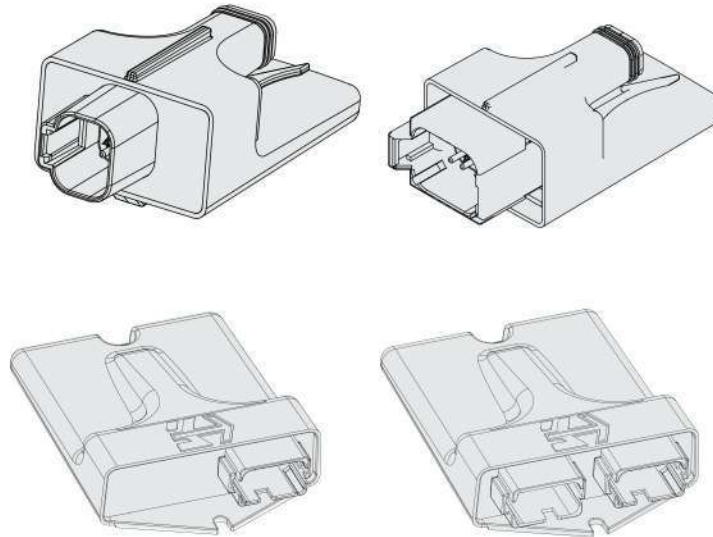

Make	Model	Page
Hydraforce	ECDR-0101A	82
Hydraforce	ECDR-0201A	84
Hydraforce	ECDR-0203A	86
Hydraforce	ECDR-0506A	88

Due to fluctuations in the Australian dollar and the economic climate, please be advised that all prices are subject to change. Please contact us to confirm pricing.

**Charles:**

**Mobile** 0418 641 566

**Email** sales@catford.com.au

**Web** www.catford.com.au





## ECDR-0101A Dual/Single Valve Driver, Plug-In Style

### Description

A compact plug-in style, microprocessor based valve driver designed for use in hydraulic proportional valve applications. Configurable to drive a single coil using an independent signal. The ECDR-0101A proportionally controls one coil to a user-defined metering profile. It is configured with HF-Impulse software; an easy-to-use, web-accessible configuration tool available as a free download at [www.hydraforce.com/electronics](http://www.hydraforce.com/electronics). An output LED indicator is located on the front.

### Operation

The controller accepts input from commonly available analog operator interface devices (joystick, potentiometer, sensors, etc.) The input signal drives the output current.

### Diagnostic Features

Any supply voltage below 8.5 VDC causes the controller to default to the valve-off mode.

The driver output drops and holds at the inactive stand-by condition. Any short or open circuit condition is automatically detected as an error.

### Ratings

Operating Temperature	-40 to 85°C (-40 to 185°F)
Molded Enclosure Dimensions	Width: 46.6 mm (1.84 in.) Height: 88.3 mm (3.48 in.) Depth: 33.9 mm (1.34 in.)
Mating Connectors	Deutsch DT06-4S and DT04-2P
Power Requirements	9 to 32 VDC
Control Inputs - Analog	Voltage: 0 to 5 or 0 to 10 VDC Current: 0 to 20 or 4 to 20 mA Resistive: 0 to 6000 ohms Temperature: ERT 120 (HydraForce temperature sensor)
Control Inputs - Digital:	Switch: Switch to battery, switch to open, switch to ground PWM: 0 to 100%, 60 to 5000 Hz Frequency: 4 to 10,000 Hz
Control Outputs	Current: 0 to 2000 mA PWM: 0-100% duty cycle; 40 to 400 Hz Output Indicator: Single LED
Weight	0.079 kg (0.175 lb) without connectors



## ECDR-0101A Dual/Single Valve Driver, Plug-In Style (continued)

### Connections & Wiring

Description	Interface	Pin	Mating Connector
Battery, 9-32 V	Power + Power -	3 2	DT06-4S
Serial TTL and Voltage/Current, Resistance Input	Serial in	4	DT06-4S
Serial TTL (For Configuration Only)	Serial out	1	DT06-4S
Solenoid	Sol A + Sol A -	1 2	DT01-4P

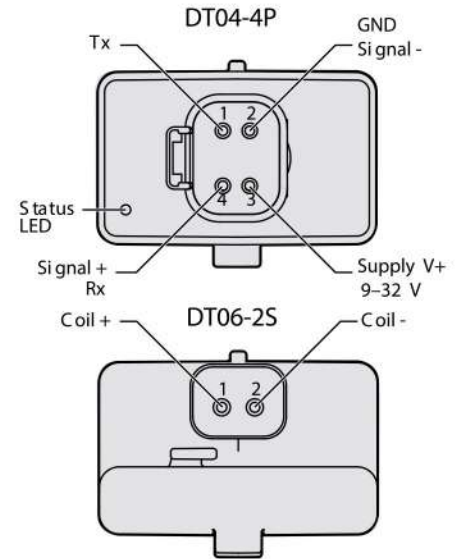

### Dimensions & Mounting

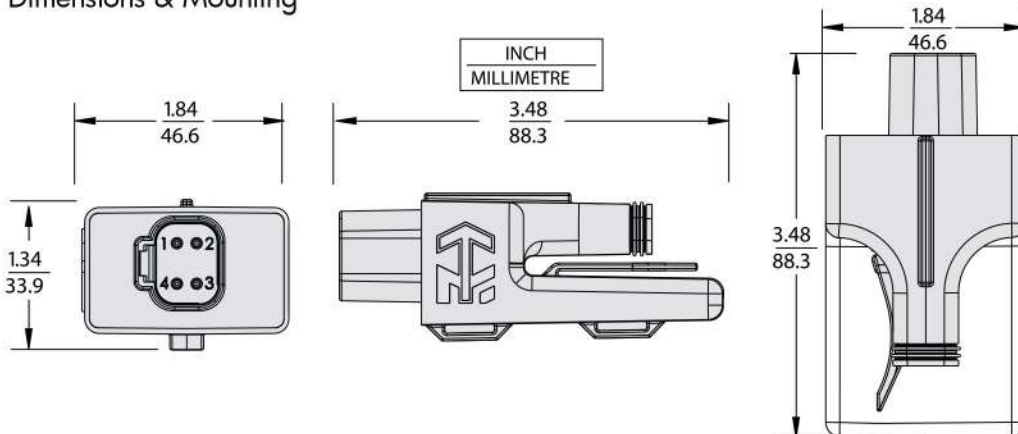

Part Number	Description	Price (Ex. GST)
ECDR-0101A	Valve Driver	
4000286	Test Harness	
4000285	USB-CAN Adaptor	

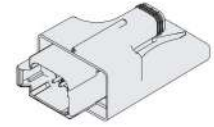

## ECDR-0201A Dual/Single Valve Driver, Plug-In Style

### Description

A compact plug-in style, microprocessor based valve driver designed for use in hydraulic proportional valve applications. Configurable to drive either one or two coils using SAE J1939 CAN or CAN Open input or an independent signal.

The ECDR-0201A proportionally controls one or two coils to a user-defined metering profile. It is configured with HF-Impulse software; an easy-to-use, web-accessible configuration tool available as a free download at [www.hydraforce.com/electronics](http://www.hydraforce.com/electronics).

### Operation

The controller accepts input from commonly available analog or SAE J1939 CAN / CAN Open operator interface devices (joystick, potentiometer, sensors, etc.) The input signal drives the output current.

### Diagnostic Features

Any supply voltage below 8.5 VDC causes the controller to default to the valve-off mode.

The driver output drops and holds at the inactive stand-by condition. Any short or open circuit condition is automatically detected as an error.

### Ratings

Operating Temperature	-40 to 85°C (-40 to 185°F)
Molded Enclosure Dimensions	Width: 46.7 mm (1.84 in.) Height: 87.8 mm (3.46 in.) Depth: 34.0 mm (1.34 in.)
Mating Connectors	Deutsch DT06-8SA and DT04-2P
Power Requirements	9 to 32 VDC
Control Inputs - Analog	Voltage: 0 to 5 or 0 to 10 VDC Current: 0 to 20 or 4 to 20 mA Resistive: 0 to 6000 ohms Temperature: ERT 120 (HydraForce temperature sensor)
Control Inputs - Digital	Switch: Switch to battery, switch to open, switch to ground PWM: 0 to 100%, 60 to 5000 Hz Frequency: 4 to 10 000 Hz
Control Outputs	Current: 0 to 2000 mA PWM: 0-100% duty cycle; 40 to 400 Hz Output Indicator: Two LED
CAN Inputs / Outputs	SAE J1939 CAN Open PDO
Weight	0.079 kg (0.175 lb) without connectors



## ECDR-0201A Dual/Single Valve Driver, Plug-In Style (continued)

### Connections & Wiring

Description	Interface	Pin	Mating Connector
Battery	Power + Power -	1 8	DT06-08SA
Voltage/Current/Resistance/ Control Signal	Signal in Gnd	2 7	DT06-08SA
CAN/J1939 Communication	CAN_HI CAN_LO	3 6	DT06-08SA
External Solenoid	Sol A + Sol A -	4 5	DT06-08SA
Integral Solenoid	Sol A + Sol A -	1 2	DT04-2P

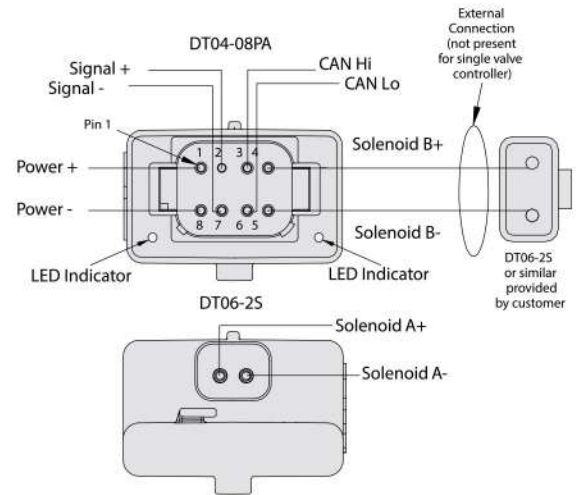

### Dimensions & Mounting

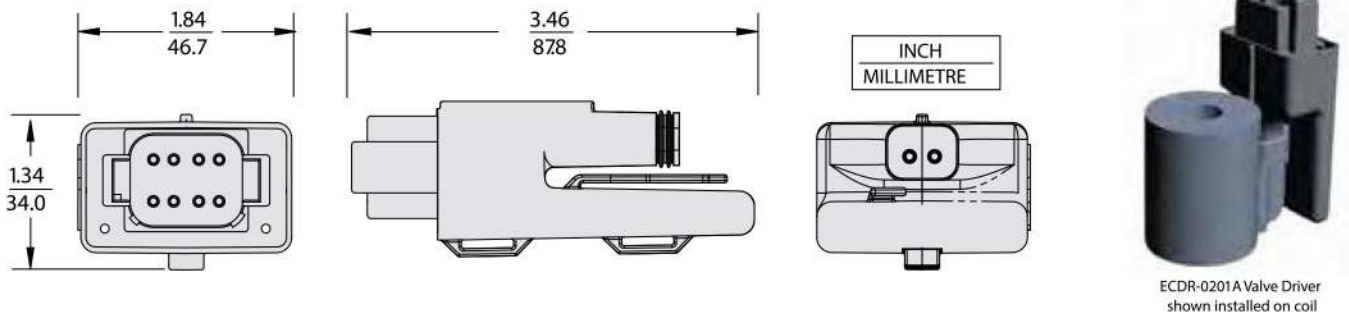

Part Number	Description	Price (Ex. GST)
ECDR-0201A	Valve Driver	
4000304	Test Harness	
4001955	Connector Kit	
4000371	USB-CAN Adaptor	



## ECDR-0203A Electronic Driver, CAN Capable

### Description

The ECDR-0203A is a robust electronic driver for solenoid-operated proportional valves. Its 32-bit processor provides high calculating power. It has three inputs that are configurable to multiple settings ranging from digital to analog. Two outputs, including one PWM closed loop output and one PWM open loop output, have configurable frequency. A single CAN bus allows CAN open and SAE J1939 communication protocols. The red / green LED signal provides quick status check. The molded enclosure has a scratch-resistant finish.

ECDR-0203A is configured with HF-Impulse software: an easy to use, web-accessible configuration tool available as a free download at [www.hydraforce.com/electronics](http://www.hydraforce.com/electronics).

### Operation

The controller accepts input from commonly available analog or SAE J1939 CAN / CAN open operator interface devices (joystick, potentiometer, sensors, etc.) The input signal drives the output current.

### Diagnostic Features

Internal diagnostics make it possible to detect overvoltage and undervoltage conditions and coil failure conditions. Outputs have short-circuit protection. Supply voltage below 9 VDC or above 32 VDC will cause the controller to go to the safe mode of valve OFF and automatically resets.

The bi-color red / green LED provides quick status check.

### Ratings

Power Requirements	9 to 32 VDC
Maximum Total Amperage	4 Amps
Processor	ARM 32-bit Cortex™-M4 CPU, 72 MHz
Memory	Flash total 128 kB; RAM 32 kB
Operating Temperature:	-40 to 85 °C (-40 to 185 °F)
Molded Enclosure Dimensions:	Width: 10.79 cm (4-1/4 in.) Height: 15.25 cm (6 in.) Depth: 3.17 cm (1-1/4 in.)
Mating Connectors (1)	Deutsch DT06-12SA
Control Inputs (3 Multi-Function Input)	Voltage: 0 to 5 or 0 to 10 VDC Current: 0 to 20 mA or 4 to 20 mA Resistive: 0 to 6k ohms Temperature: ERT 120 (HydraForce temperature sensor) Digital: Switch to ground, switch to supply, floating PWM: 0 to 100%, 60 to 5000 Hz Frequency: 4 to 10,000 Hz
Communication/ Interfaces (1)	CAN 2.0 B
Control Outputs: (2 - can be configured open or closed loop)	Current: sourcing, 2 amps continuous PWM: 40 to 400 Hz
Sealing:	IP67 rated
Housing	Noryl™ glass-filled PPE /PPO, filled with potting compound
Weight	366 g (0.8 lb)



## ECDR-0203A Electronic Driver, CAN Capable (continued)

### Connections & Wiring

Grey plug - X1	
Description	Pin
Supply voltage	X1.1
Signal ground	X1.2
Output 1 +	X1.3
Output 1 -	X1.4
Output 2 +	X1.5
Output 2 -	X1.6
Input 3 signal	X1.7
CAN Low	X1.8
CAN High	X1.9
Input 1 signal	X1.10
Input 2 signal	X1.11
Supply voltage ground	X1.12

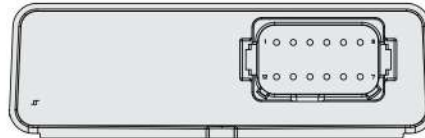

X1 (grey)

### Dimensions & Mounting

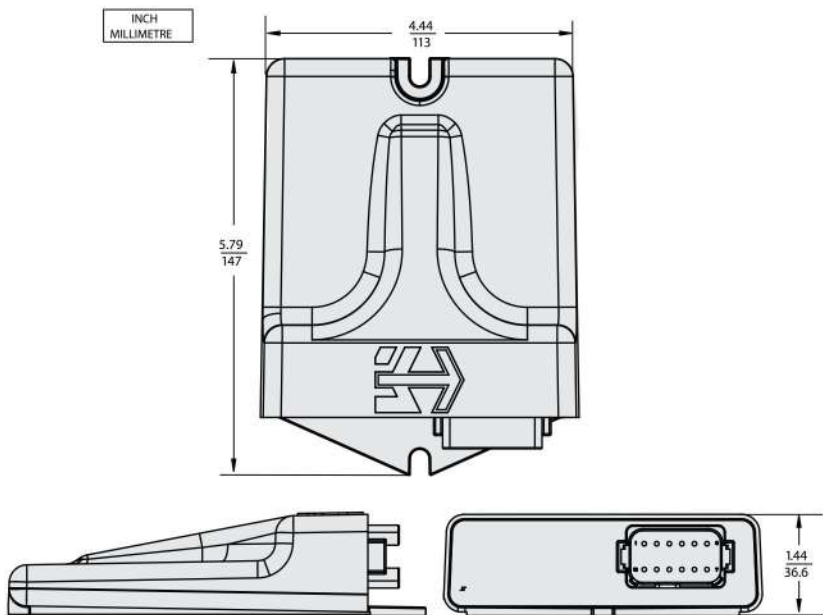

Part Number	Description	Price (Ex. GST)
ECDR-0203A	Valve Driver	
4000307	Test Harness	
4001956	Connector Kit	
4000371	USB-CAN Adaptor	





## ECDR-0506A Electronic Driver, CAN Capable

### Description

The ECDR-0506A is a robust electronic driver for solenoid-operated proportional valves. Its 32-bit processor provides high calculating power. It has six inputs that are configurable to multiple settings ranging from digital to analog. Five outputs, including four PWM closed loop outputs and one PWM open loop output, have configurable frequency. A single CAN bus allows CAN Open and SAE J1939 communication protocols. The red / green LED signal provides quick status check. The molded enclosure has a scratch-resistant finish.

ECDR-0506A is configured with HF-Impulse software: an easy to use, web-accessible configuration tool available as a free download at [www.hydraforce.com/electronics](http://www.hydraforce.com/electronics).

### Operation

The controller accepts input from commonly available analog or SAE J1939 CAN / CAN Open operator interface devices (joystick, potentiometer, sensors, etc.) The input signal drives the output current.

### Diagnostic Features

Internal diagnostics make it possible to detect overvoltage and undervoltage conditions and coil failure conditions.

Outputs have short-circuit protection.

Supply voltage below 9 VDC or above 32 VDC will cause the controller to go to the safe mode of valve OFF and automatically resets.

The bi-color red / green LED provides quick status check.

### Application Notes

The ECDR-0506A controller can be used in a wide range of applications, including transmission controls, vehicle traction controls, joystick controls, and harvesting function controls.

It can be specified for applications previously using the HydraForce EVDR4, EVDR5 or EVDR7.

### Ratings

Power Requirements	9 to 32 VDC; Maximum Total Amperage: 10 Amps
Processor	ARM 32-bit Cortex™-M4 CPU, 72 MHz
Memory	Flash total 128 kB; RAM 32 kB
Operating Temperature	-40 to 85°C (-40 to 185°F)
Molded Enclosure Dimensions	Width: 10.79 cm (4-1/4 in.) Height: x 15.25 (6 in.) Depth: 3.17 cm (1-1/4 in.)
Mating Connectors (2)	Deutsch DT06-12SA and DT06-12SB
Control Inputs (4 Multi-Function Input)	Voltage: 0 to 5 or 0 to 10 VDC Current: 0 to 20 mA or 4 to 20 mA Resistive: 0 to 6k ohms Temperature: ERT 120 (HydraForce temperature sensor) Digital: Switch to ground, switch to supply, floating
Control Inputs (2 Multi-Function Input)	Digital: Switch to ground, switch to supply PWM: 0 to 100%, 60 to 5000 Hz Frequency: 4 to 10,000 Hz
Communication/ Interfaces (1)	CAN 2.0 B
Control Outputs (4 closed loop)	Current: sourcing, 2 amps continuous PWM: 40 to 400 Hz
Control Outputs (1 open loop)	Current: sourcing, 2 amps continuous PWM: 40 to 400 Hz
Sensor Power Supply	+5 V 200 mA
Sealing	IP67 rated
Housing	Noryl™ glass-filled PPE/PPO, filled with potting compound
Weight	366 g (0.8 lb)



## ECDR-0506A Electronic Driver, CAN Capable (continued)

### Connections & Wiring

Black plug - X2		Grey plug - X1	
Description	Pin	Description	Pin
Output 3 -	X2.1	Supply voltage	X1.1
Output 4 +	X2.2	Signal ground	X1.2
Output 4 -	X2.3	Output 1 +	X1.3
Output 5 +	X2.4	Output 1 -	X1.4
Output 5 -	X2.5	Output 2 +	X1.5
Input 5 signal	X2.6	Output 2 -	X1.6
Input 6 signal	X2.7	+5 V supply	X1.7
Input 3 signal	X2.8	CAN Low	X1.8
Signal ground	X2.9	CAN High	X1.9
Input 4 signal	X2.10	Input 1 signal	X1.10
Signal ground	X2.11	Input 2 signal	X1.11
Output 3 +	X2.12	Supply voltage ground	X1.12

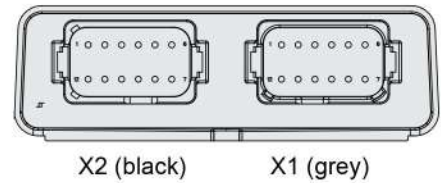

### Dimensions & Mounting

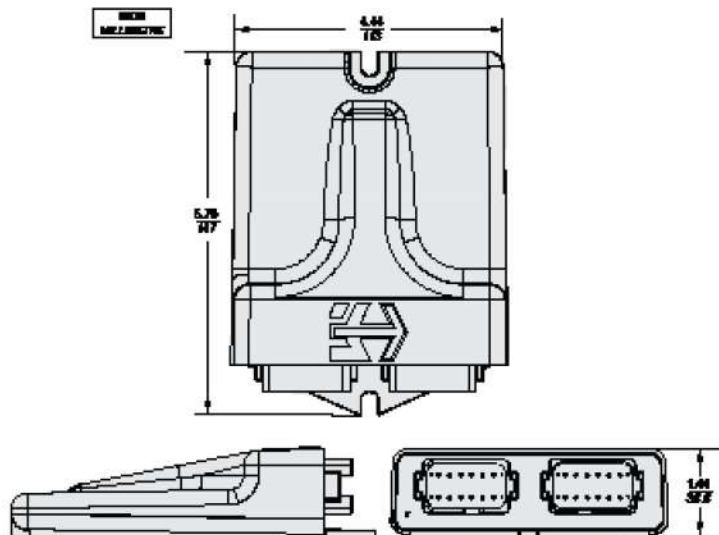

Part Number	Description	Price (Ex. GST)
ECDR-0506A	Valve Driver	
4000307	Test Harness X1	
4000308	Test Harness X2	
4001965	Connector Kit	
4000371	USB-CAN Adaptor	